

Crash rails – straight ends – base plate

As manufacturer we can offer you the following:

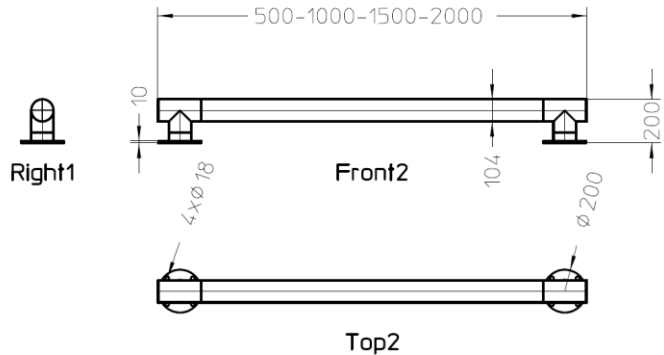

<ul style="list-style-type: none"> • Crash protection bar – straight ends • With base plate \varnothing 200 mm – 4 holes \varnothing 18 mm • Stainless steel 304/316 • polished • Total height: 200 mm • Length: 500–1000–1500–2000 mm • Tube : \varnothing 104x2 mm • Seamless finishing • Filled with concrete 	code					weight
	SB-RU-VF-104x2-200x 500 x200- rvs 304 -beton					20 kg
	SB-RU-VF-104x2-200x 500 x200- rvs 316 -beton					20 kg
	SB-RU-VF-104x2-200x 1000 x200- rvs 304 -beton					32 kg
	SB-RU-VF-104x2-200x 1000 x200- rvs 316 -beton					32 kg
	SB-RU-VF-104x2-200x 1500 x200- rvs 304 -beton					45 kg
	SB-RU-VF-104x2-200x 1500 x200- rvs 316 -beton					45 kg
	SB-RU-VF-104x2-200x 2000 x200- rvs 304 -beton					57 kg
	SB-RU-VF-104x2-200x 2000 x200- rvs 316 -beton					57 kg

These are the most ordered sizes. Other dimensions are also possible.

For orders and price requests you can email us on : info@axra.be

